

NIPX-Series IP PBX

KYLINK COMMUNICATIONS CO., LTD.
TEL : 886-2-32349898 FAX : 886-2-8228-1199



Introduction

NIPX-Series is a new digital wireless IP PABX which integrating DSP, DECT, GSM and Voice over IP technologies. NIPX-128 , NIPX-1000S and NIPX-1000 are 3 models that capable from 16 up to 7168 ports . The advantage emphasizes on competitive price, quality product and high stability for providing users perfect communication service. It also provides advanced CTI interface to meet different professional needs.

System Illustration

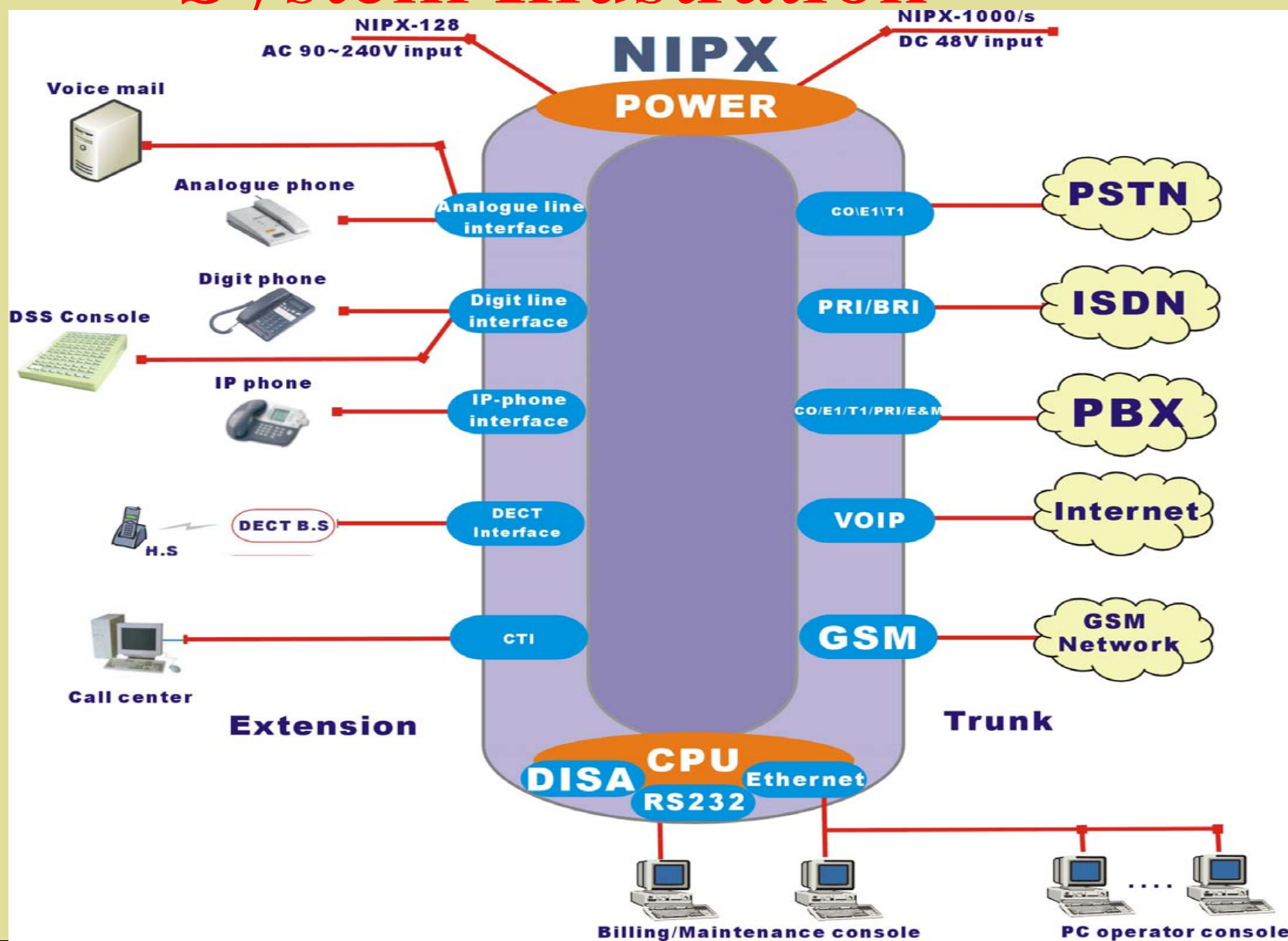



Introduction of various Interface

Trunk interface

- Center Office Trunk (COT)—16 ports/card
- E1/T1 Trunk (E1/T1)—1 E1/T1/card
- Primary Rate Interface (PRI)—1 PRI/card
- Basic Rate Interface (BRI-T)—4 ports/card
- 2W/4W E&M Trunk (E&M)—4 ports/card
- Global System Mobile (GSM)—6 ports/card
- VoIP Trunk Interface (SIP/H.323)—8 channels/card
- VoIP Trunk Interface (SIP)—32channels/card



Introduction of various Interface

Subscriber interface

- Analog-phone Line Card (ALC)—16 ports/card
- Key-phone Line Card (KLC)—16 ports/card
- IP-phone Line Card (SIP)—8 ports/card
- DECT Interface Card (DIC)—4 B.S/card

Peripheral device interface

- RS-232 port—for maintenance & billing console
- Ethernet port—for maintenance & billing & PC operator console
- CTI—for call center application



- Digital Key-telephone

- provide 1B+D signal, communicate distance exceeds 600 meters from system.
- 16 x 2 LCD screen, displaying operation status and calling in/out number etc.
- 24 programmable keys and 11 function keys for friendly operation –don't disturb, call forward....
- date and caller number of missed call can be recorded automatically and distinguished from message lamp.
- 2 wires connection from main unit.



- Attendant Console

- Both digit phone + DSS and PC console for your alternative.
- With 6 loop control keys and Trunk Queue function. It can display trunk-waiting figure.
- With LCD display to show Calling in/out number, service class, trunk number, extension/trunk status, alarm...etc.
- Authorized login password as for operators. Anyone can be part-time operator .



- **Maintenance Console**

- Utilize Windows graphic user operation interface.
- Both RS-232 or Ethernet to accomplish local or remote access.
- Auto diagnose and report to PC moreover to your e-mail address if Ethernet connected .
- Authorized password login and record for administrator .
- Within 4 grades of authorized password to ensure safety of operation .



- **Billing console**

- Use Windows graphic user operation interface.
- Both RS-232 or Ethernet to accomplish local or remote access.
- Record all of the call out and call in data.
- Bill report including Caller No., Called No., Transfer Extension No., Trunk No., Starting Date/Time, Duration Time, and Cost.
- The call rate can be adjusted by different area code.
- Offer reverse polarity detection or start by time.



Key features and advantages

■ Caller ID recognition

In-built caller ID detector , the caller ID can be recognized and displayed on analog , digit and IP phone without extra cost .

■ DISA

In NIPX series , it can be mounted on CPU card as a daughter board that provides multi-languages voice guidance which serves different voice content in 6 time period.

■ BRA/PRA

NIPX series provide Euro standard ISDN PRI/BRI T interface connect to ISDN network.



Key features and advantages

■ DECT wireless

Comply with GAP standard.

Can be configured as wireless PBX or wireless controller system.

Features of handover and roaming.

■ GSM interface

Support 900/1800Hz GSM network.

Least cost routing automatically.

■ VOIP

Support SIP/H.323 protocol.

VOIP trunk and extension interface.

Configure with gateway application.



Key features and advantages

■ Maintenance console

Both RS-232 and Ethernet for remote access .
Windows GUI operation.
Authorized password login and record.

■ Billing console

Both RS-232 and Ethernet for remote access .
Windows GUI operation.
All data of call out and call in can be recorded.
The report includes Caller No., Called No. ,
Transferred Extension No. , Trunk No. , Starting
date/time , Duration and Cost.
Bill rate is adjustable.



Key features and advantages

■ Attendant Console

Key-phone + DSS console and PC operator console for your alternative.

Authorized key-phone can login as an attendant console , no specific operator needed.

■ CTI application

Providing TSAPI driver for developing application software.

Providing software for call center application.

Providing software for IVR application.



Key features and advantages

■ Flexible expansion

All interface cards can be used in the series , flexible extend from 16 to 7168 ports.

■ Reliable quality

Duplicate Power , CPU and Switching designed for NIPX-1000 and NIPX-1000S to ensure reliability.

Wireless Application

- Wireless PBX

-The wireless solution of NIPX-Series was adopted DECT Micro-Cell structure, the maximum coverage of the system can reach 64 cells totally. And accomplish CLID, Handover and Roaming...etc.

-Wireless Controller

While taking NIPX-Series as a Wireless Controller, it can provide analog interface to connect with any brand of existing PABX to carry out DECT wireless application.

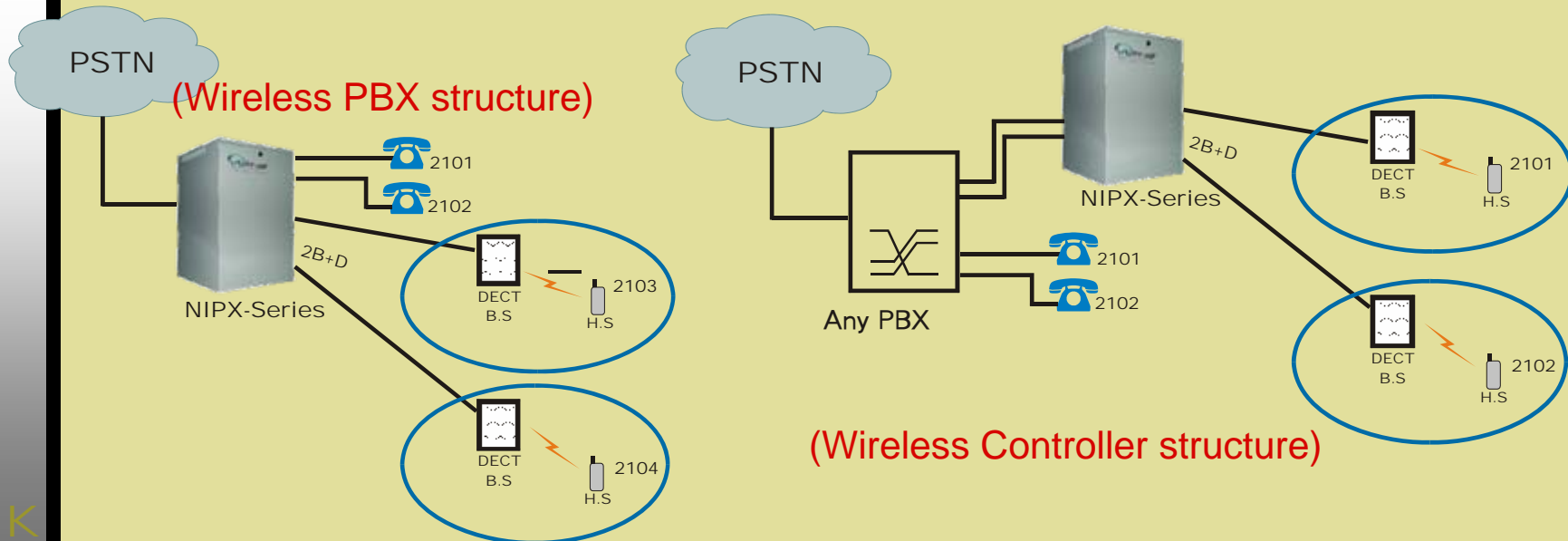

VPN Application

Virtual Private Network for multinational enterprise

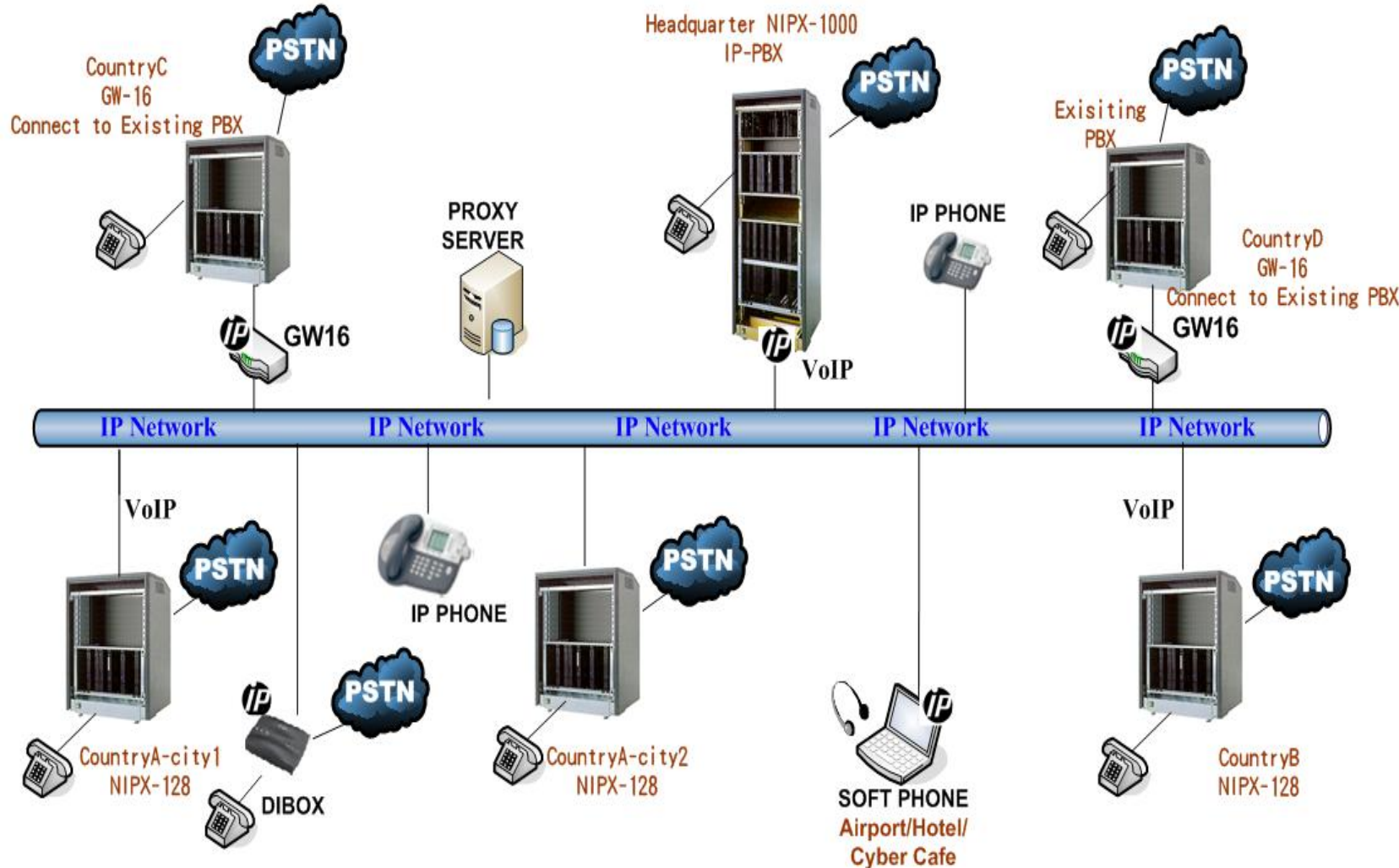

Remote Switch Units Application

Remote Switch Unit for multi-building campus

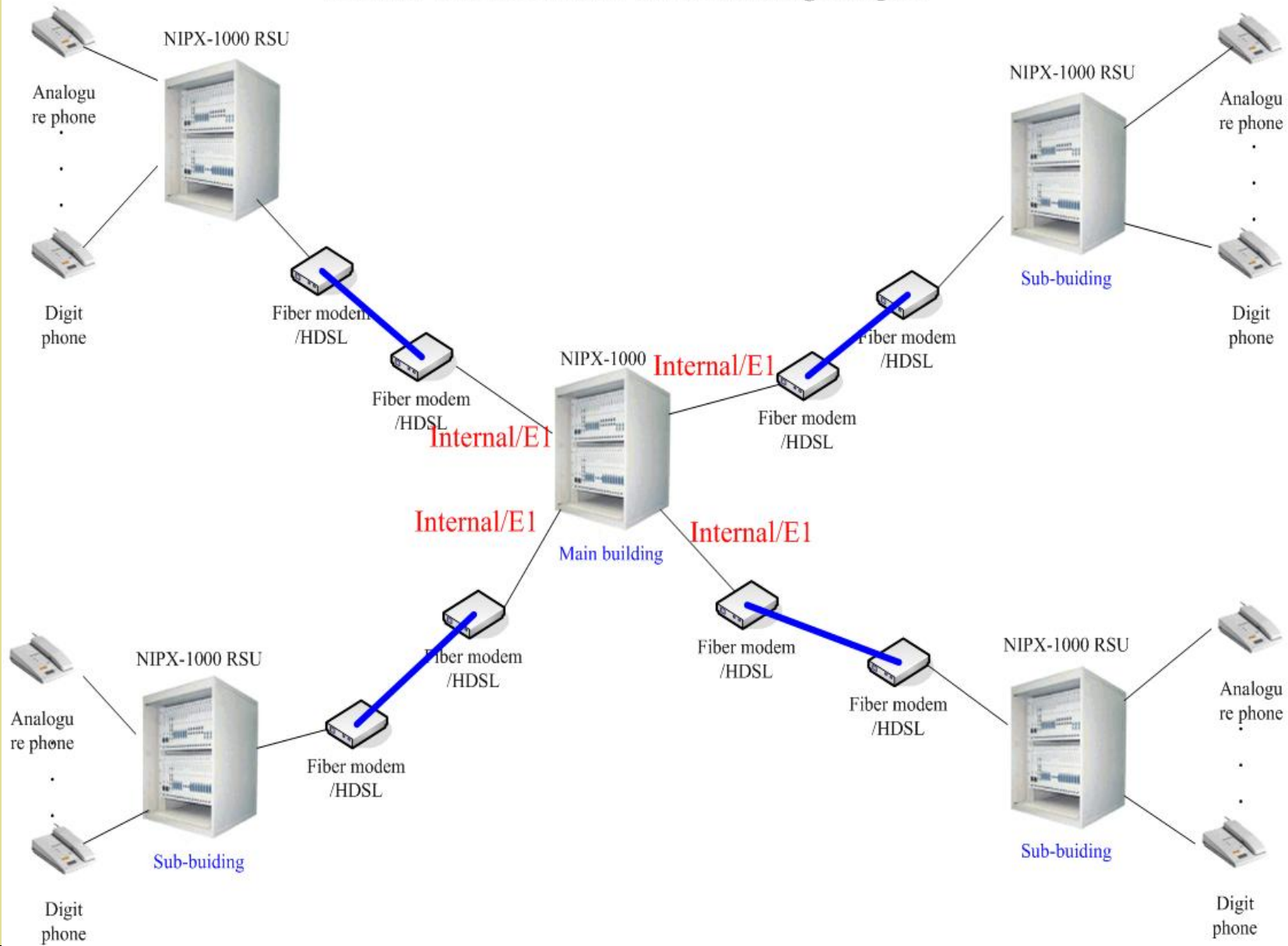

Call Center Application

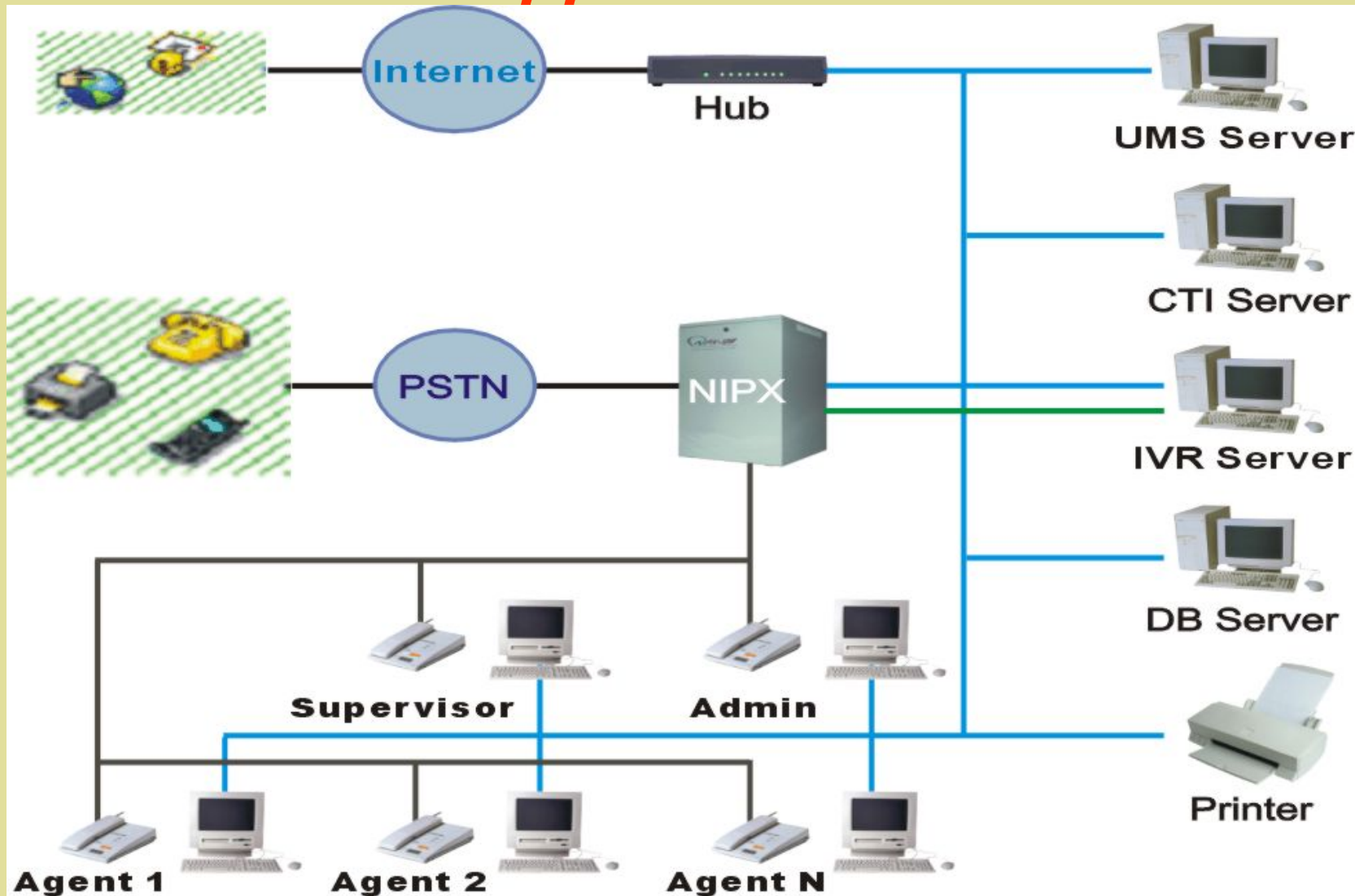



Advantages of NIPX Series from competitors

- Provides GSM interface; to concentrate and reduce GSM calling cost.
- Provides E1/T1, PRI and BRI-T interfaces; it can make diversity of networks.
- Provides Caller ID function; Keyphone and Single phone all can display Caller ID.
- Provides VoIP interface; it can make a VPN network which makes free calls within the VPN network around the world.
- Provides CTI TSAPI interface for partner to develop Call Center or to purchase KY's Call Center as optional.
- Provides PC console and key phone + DSS for operator.
- NIPX Series adopts the universal slots for interface cards, it has flexible capacity from 16 to 7168 ports for your expansion.



THANK YOU

